

<b>DTC</b>	<b>P0351</b>	<b>IGNITION COIL "A" PRIMARY/SECONDARY CIRCUIT</b>
------------	--------------	--

<b>DTC</b>	<b>P0352</b>	<b>IGNITION COIL "B" PRIMARY/SECONDARY CIRCUIT</b>
------------	--------------	--

<b>DTC</b>	<b>P0353</b>	<b>IGNITION COIL "C" PRIMARY/SECONDARY CIRCUIT</b>
------------	--------------	--

<b>DTC</b>	<b>P0354</b>	<b>IGNITION COIL "D" PRIMARY/SECONDARY CIRCUIT</b>
------------	--------------	--

## CIRCUIT DESCRIPTION

### HINT:

- These DTCs indicate malfunction related to the primary circuit.
- If DTC P0351 is displayed, check No.1 ignition coil with igniter circuit.
- If DTC P0352 is displayed, check No.2 ignition coil with igniter circuit.
- If DTC P0353 is displayed, check No.3 ignition coil with igniter circuit.
- If DTC P0354 is displayed, check No.4 ignition coil with igniter circuit.

A Direct Ignition System (DIS) is used on this vehicle. The DIS improves the ignition timing accuracy, reduces high-voltage loss, and enhances the overall reliability of the ignition system by eliminating the distributor. The DIS is a 1-cylinder ignition system which ignites one cylinder with one ignition coil. In the 1-cylinder ignition system, the one spark plug is connected to the end of the secondary winding. High voltage generated in the secondary winding is applied directly to the spark plug. The spark of the spark plug passes from the center electrode to the ground electrode.

The ECM determines the ignition timing and outputs the ignition signals (IGT) for each cylinder. Using the ignition (IGT) signal, the ECM turns on and off the power transistor inside the igniter and this switches on and off the current to the primary coil. When the current flow to the primary coil is cut off, high-voltage is generated in the secondary coil and this voltage is applied to the spark plugs to spark inside the cylinders. As the ECM cuts the current to the primary coil, the igniter sends back the ignition confirmation (IGF) signal for each cylinder ignition to the ECM.

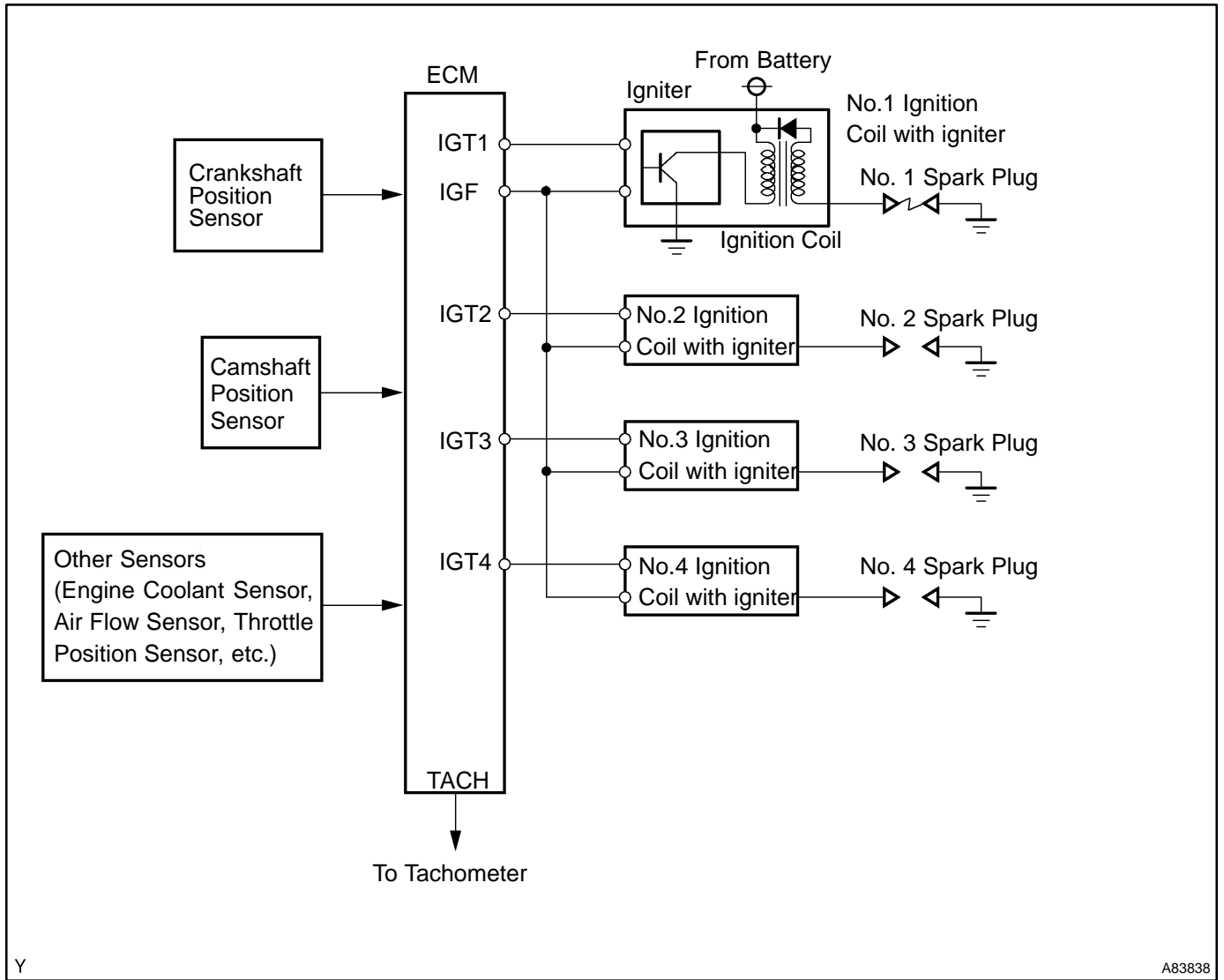

Y

A83838

DTC No.	DTC Detection Condition	Trouble Area
P0351 P0352 P0353 P0354	No IGF signal to ECM while engine is running	<ul style="list-style-type: none"> <li>• Ignition system</li> <li>• Open or short in IGF or IGT circuit from ignition coil with igniter to ECM (ignition coil circuit 1 through 4)</li> <li>• Ignition coil with igniter (ignition coil circuit 1 through 4)</li> <li>• ECM</li> </ul>

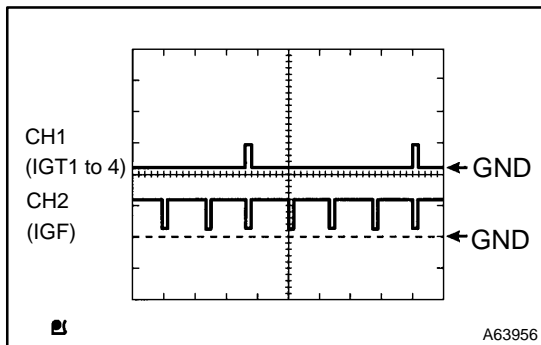

A63956

Reference: Inspection using the oscilloscope.

HINT:

The correct waveform is as shown on the left.

Item	Contents
Terminal	CH1: IGT1, IGT2, IGT3, IGT4 - E1 CH2: IGF - E1
Equipment Setting	2V/Division, 20ms/Division
Condition	While the engine is cranking or idling

### MONITOR DESCRIPTION

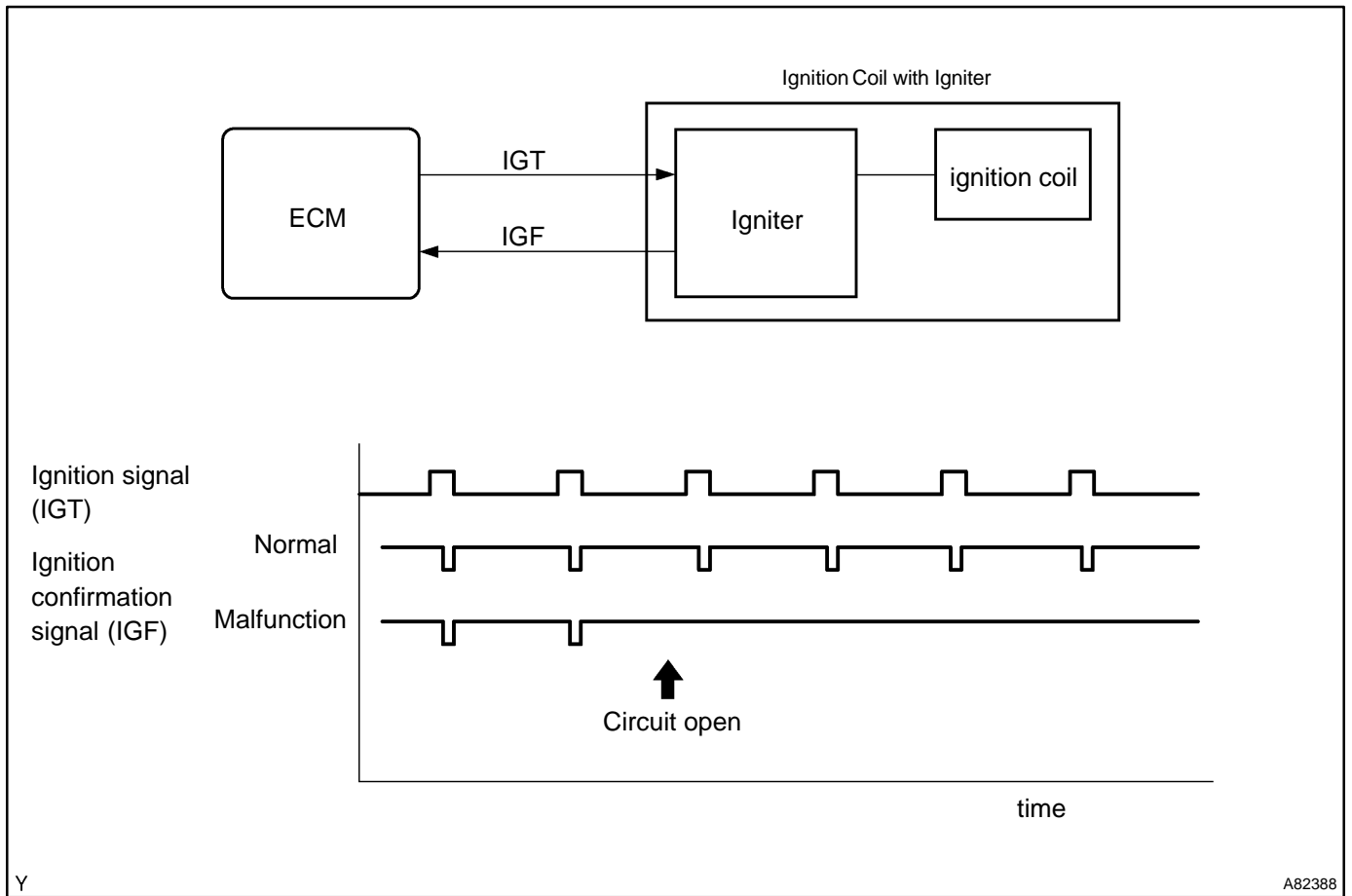

If the ECM does not receive the ignition confirmation signal (IGF) after sending the ignition signal (IGT), the ECM interprets this as a fault in the igniter and sets a DTC.

### MONITOR STRATEGY

Related DTCs	P0351	No. 1 ignition coil with igniter circuit malfunction
	P0352	No. 2 ignition coil with igniter circuit malfunction
	P0353	No. 3 ignition coil with igniter circuit malfunction
	P0354	No. 4 ignition coil with igniter circuit malfunction
Required sensors/components	Igniter	
Frequency of operation	Continuous	
Duration	0.256 sec	
MIL operation	Immediately	
Sequence of operation	None	

## TYPICAL ENABLING CONDITIONS

Item	Specification	
	Minimum	Maximum
The monitor will run whenever the following DTCs are not present	See "List of Disable a Monitor" table (On page 05-24)	
Engine speed	-	1,500 rpm
Either following condition is met:	(a) or (b)	
(a) Following conditions are met:	1 & 2	
1. Engine speed	-	500 rpm
2. Battery voltage	6 V	-
(b) Following conditions are met:	1 & 2	
1. Engine speed	500 rpm	-
2. Battery voltage	10 V	-

## TYPICAL MALFUNCTION THRESHOLDS

Detection Criteria	Threshold
"Ignition signal fail count"	More than 2
"Ignition signal fail count" is as follows:	When IGF should have returned despite sending IGT.

## COMPONENT OPERATING RANGE

Standard Value
Confirmed signal number = ignition signal number

# WIRING DIAGRAM

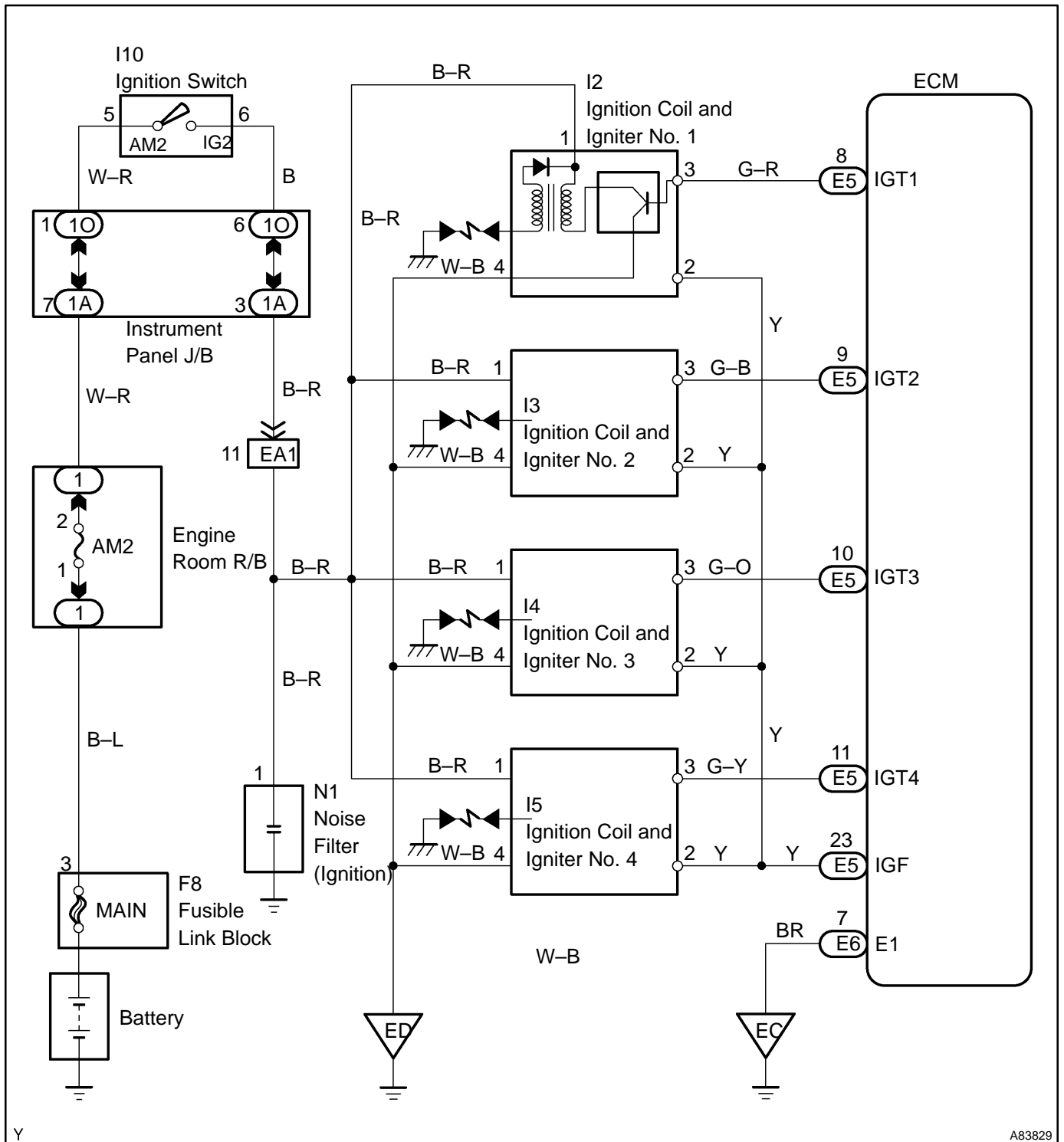

Y

A83829

## INSPECTION PROCEDURE

**HINT:**

Read freeze frame data using the hand-held tester or the OBD II scan tool. Freeze frame data records the engine conditions when a malfunction is detected. When troubleshooting, it is useful for determining whether the vehicle was running or stopped, the engine was warmed up or not, the air-fuel ratio was lean or rich, etc. at the time of the malfunction.

**1 CHECK SPARK PLUG AND SPARK OF MISFIRING CYLINDER (See page 18-1)**

**NG** Go to step 4

**OK**

**2 CHECK HARNESS AND CONNECTOR(IGNITION COIL ASSY - ECM (IGF SIGNAL TERMINAL))**

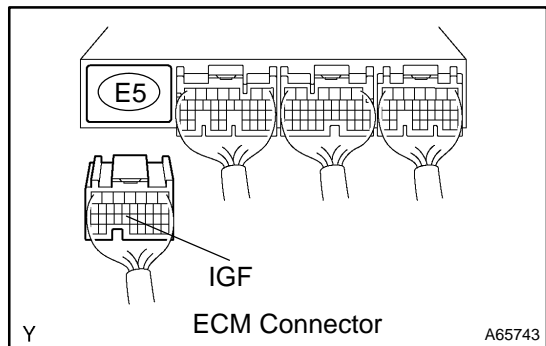

- (a) Disconnect the I2, I3, I4 or I5 ignition coil and igniter connector.
- (b) Disconnect the E5 ECM connector.
- (c) Measure the resistance between the wire harness side connectors.

**Standard (Check for open):**

Tester Connection	Specified Condition
IGF (I2-2) - IGF (E5-23)	Below 1 Ω
IGF (I3-2) - IGF (E5-23)	
IGF (I4-2) - IGF (E5-23)	
IGF (I5-2) - IGF (E5-23)	

**Standard (Check for short):**

Tester Connection	Specified Condition
IGF (I2-2) or IGF (E5-23) - Body ground	10 kΩ or higher
IGF (I3-2) or IGF (E5-23) - Body ground	
IGF (I4-2) or IGF (E5-23) - Body ground	
IGF (I5-2) or IGF (E5-23) - Body ground	

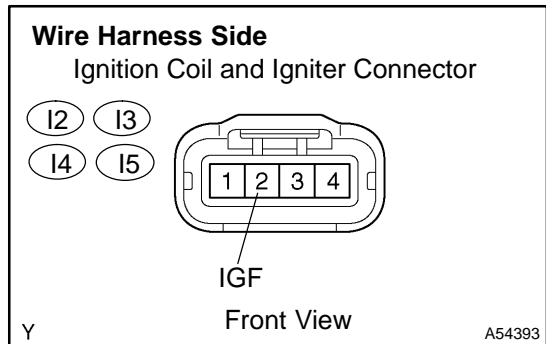

- (d) Reconnect the ignition coil and igniter connector.
- (e) Reconnect the ECM connector.

**NG** REPAIR OR REPLACE HARNESS OR CONNECTOR

**OK**

**3 INSPECT ECM(IGF VOLTAGE)**

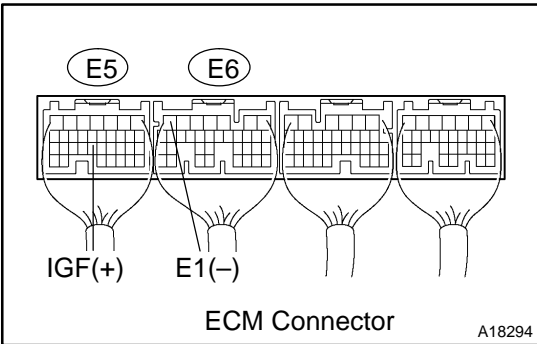

- (a) Disconnect the I2, I3, I4 or I5 ignition coil and igniter connector.
- (b) Turn the ignition switch ON.
- (c) Measure the voltage between the specified terminals of the E5 and E6 ECM connectors.

**Standard:**

Tester Connection	Specified Condition
IGF (E5-23) - E1 (E6-7)	4.5 to 5.5 V

- (d) Reconnect the ignition coil and igniter connector.

**NG** → **REPLACE ECM (See page 10-17)**

**OK**

**REPLACE IGNITION COIL NO.1**

**4 CHECK HARNESS AND CONNECTOR(IGNITION COIL ASSY - ECM (IGT SIGNAL TERMINAL))**

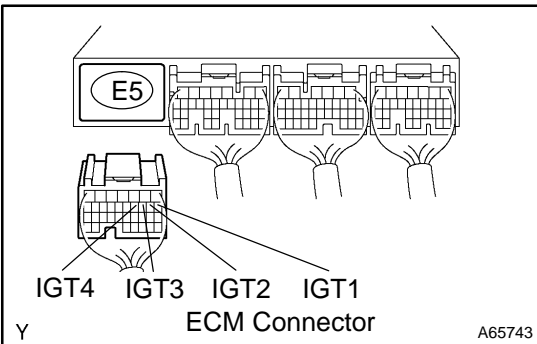

- (a) Disconnect the I2, I3, I4 or I5 ignition coil and igniter connector.
- (b) Disconnect the E5 ECM connector.
- (c) Measure the resistance between the wire harness side connectors.

**Standard (Check for open):**

Tester Connection	Specified Condition
IGT (I2-3) - IGT1 (E5-8)	Below 1 Ω
IGT (I3-3) - IGT2 (E5-9)	
IGT (I4-3) - IGT3 (E5-10)	
IGT (I5-3) - IGT4 (E5-11)	

**Standard (Check for short):**

Tester Connection	Specified Condition
IGT (I2-3) or IGT1 (E5-8) - Body ground	10 kΩ or higher
IGT (I3-3) or IGT2 (E5-9) - Body ground	
IGT (I4-3) or IGT3 (E5-10) - Body ground	
IGT (I5-3) or IGT4 (E5-11) - Body ground	

- (d) Reconnect the ignition coil and igniter connector.
- (e) Reconnect the ECM connector.

**NG** → **REPAIR OR REPLACE HARNESS OR CONNECTOR**

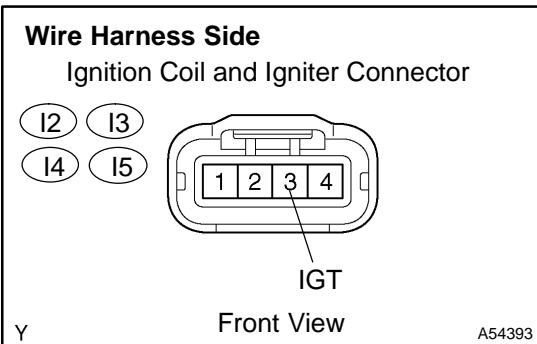

**OK**

**5 INSPECT ECM(IGT1, IGT2, IGT3 OR IGT4 VOLTAGE)**

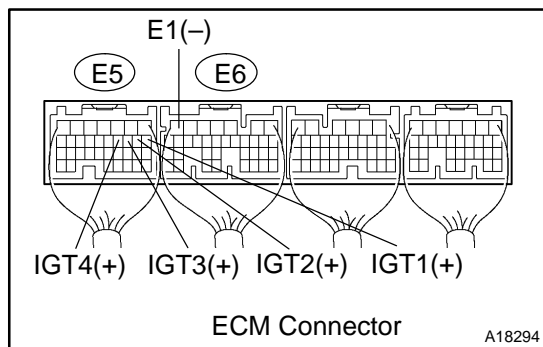

- (a) Measure the voltage between the applicable terminals of the E5 and E6 ECM connectors when the engine is cranked.

**Standard:**

Tester Connection	Specified Condition
IGT1 (E5-8) – E1 (E6-7)	Between 0.1 V and 4.5 V
IGT2 (E5-9) – E1 (E6-7)	
IGT3 (E5-10) – E1 (E6-7)	
IGT4 (E5-11) – E1 (E6-7)	

**NG** → **REPLACE ECM (See page 10-17)**

**OK**

**6 INSPECT ECM(IGT1, IGT2, IGT3 OR IGT4 VOLTAGE)**

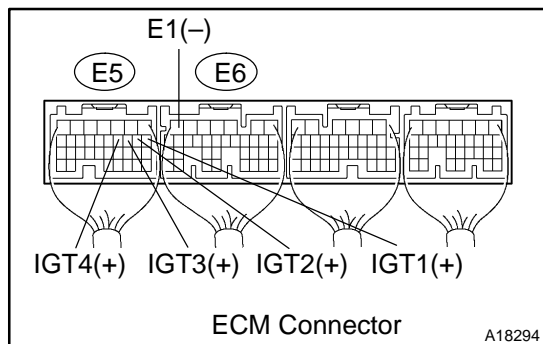

- (a) Disconnect the I2, I3, I4 or I5 ignition coil and igniter connector.
- (b) Measure the voltage between the applicable terminals of the E5 and E6 ECM connectors when the engine is cranked.

**Standard:**

Tester Connection	Specified Condition
IGT1 (E5-8) – E1 (E6-7)	4.5 V or more
IGT2 (E5-9) – E1 (E6-7)	
IGT3 (E5-10) – E1 (E6-7)	
IGT4 (E5-11) – E1 (E6-7)	

- (c) Reconnect the ignition coil and igniter connector.

**NG** → **REPLACE ECM (See page 10-17)**

**OK**

**7 INSPECT IGNITION COIL NO.1(POWER SOURCE)**

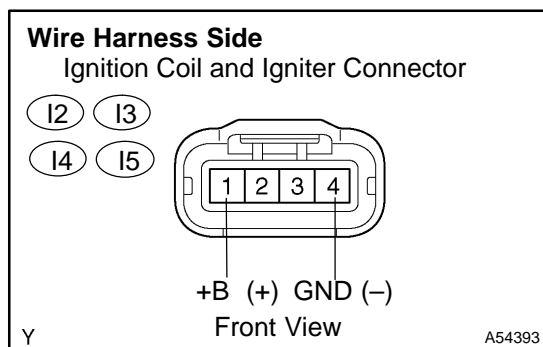

- (a) Disconnect the I2, I3, I4 or I5 ignition coil and igniter connector.
- (b) Turn the ignition switch ON.
- (c) Measure the voltage between the terminal of the wire harness side connector and body ground.

**Standard:**

Tester Connection	Specified Condition
+B (I2-1) – GND (I2-4)	9 to 14 V
+B (I3-1) – GND (I3-4)	
+B (I4-1) – GND (I4-4)	
+B (I5-1) – GND (I5-4)	

- (d) Reconnect the ignition coil and igniter connector.

**OK** REPLACE IGNITION COIL NO.1

**NG**

**8 CHECK HARNESS AND CONNECTOR(IGNITION COIL ASSY - IGNITION SWITCH)**

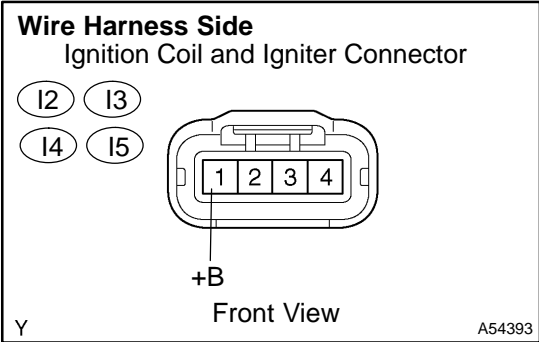

- (a) Disconnect the I2, I3, I4 or I5 ignition coil and igniter connector.
- (b) Disconnect the I10 ignition switch connector.
- (c) Measure the resistance between the wire harness side connectors.

**Standard (Check for open):**

Tester Connection	Specified Condition
+B (I2-1) - IG2 (I10-6)	Below 1 Ω
+B (I3-1) - IG2 (I10-6)	
+B (I4-1) - IG2 (I10-6)	
+B (I5-1) - IG2 (I10-6)	

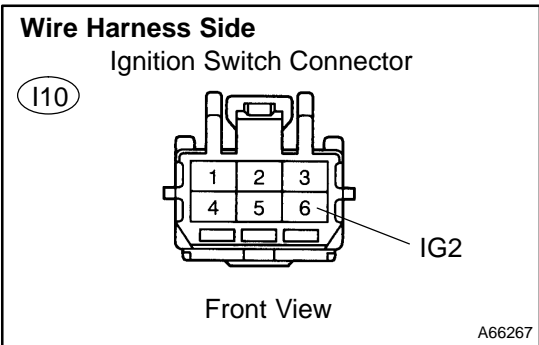

**Standard (Check for short):**

Tester Connection	Specified Condition
+B (I2-1) or IG2 (I10-6) - Body ground	10 kΩ or higher
+B (I3-1) or IG2 (I10-6) - Body ground	
+B (I4-1) or IG2 (I10-6) - Body ground	
+B (I5-1) or IG2 (I10-6) - Body ground	

- (d) Reconnect the ignition coil and igniter connector.
- (e) Reconnect the ignition switch connector.

**NG** REPAIR OR REPLACE HARNESS OR CONNECTOR

**OK**

**REPLACE IGNITION COIL NO.1**